

WEIGHT = APPROXIMATELY 91KG (200LBS)

ASSEMBLED PRECAST PARK BENCH

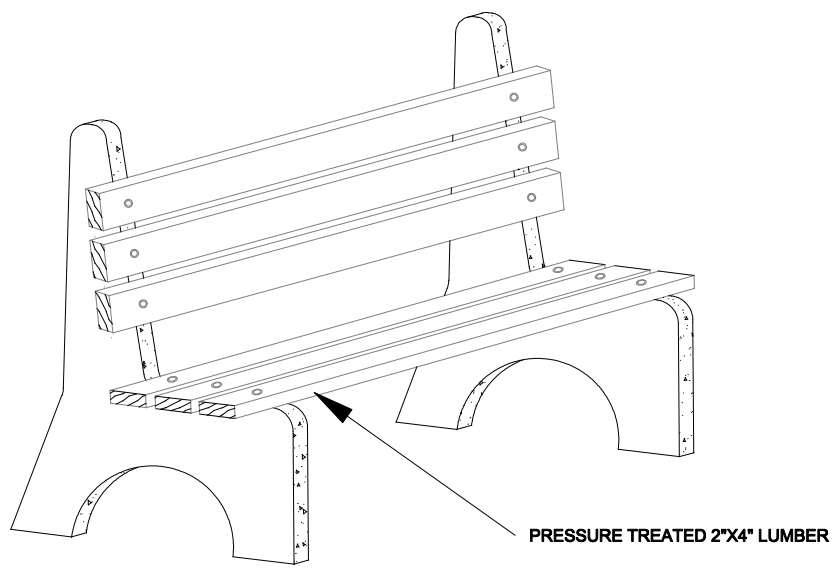

PHYSICAL PROPERTIES:
 CONCRETE MEETS REQUIREMENTS OF CSA A23.1
 COMPRESSIVE STRENGTH: Min 35MPa @ 28 Days
 CONCRETE CONTAINS 5-8% ENTRAINED AIR

NAME:
 PRECAST PARK BENCH END

PRODUCER:



Casey Concrete Ltd.